

APPLICATION:
 JOB NAME:
 QUANTITY: ITEM NO.

PRODUCT NAME:
 VACUUM BREAKER ANTI-SPILL
 SATIN CHROME
 SPECIAL CONFIGURATION
 CHECK BASE MODEL AND OPTIONS

MODEL:
 14451
 OPTIONS OR MODIFICATIONS:
 OTHER _____

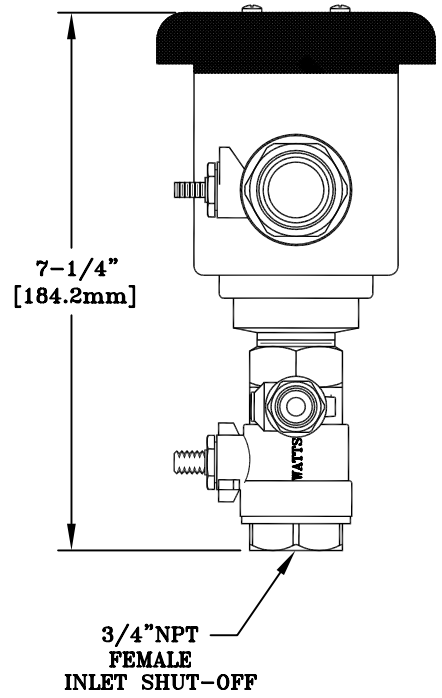
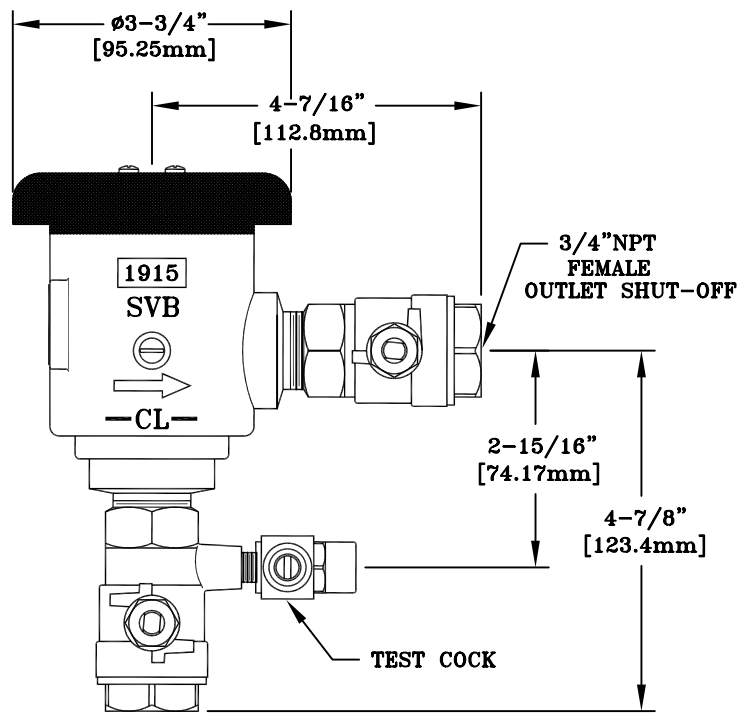

FEATURES

- * ASSE - 1056 APPROVED
- ** TESTED UNDER NSF-CSA ALLIANCE PROGRAM

RECOMMENDED SETTINGS

- * 110°F AT 80 PSI

SYSTEM LIMITS

- * TEMP: 33°F MIN. TO 180°F MAX. * PRESSURE: 100 PSI MAX. STATIC
- * PRESSURE 8 PSI (MIN) - 150 PSI (MAX)

SHIPPING WEIGHT

- * 5.0 LBS